

Description

General

The SFG-MM2 is small form factor pluggable module with standard LC duplex connector for fiber communications. This module is designed for multi-mode fiber and operates at a nominal wavelength of 1310 nm with cost effective and high performance. It is with the SFP 20-pin connector to allow hot plug capability.



Transmitter Section

The transmitter consists of a high-performance 1310 nm Fabry-Perot (FP) laser, which is housed within a metal package. In addition, this component is also class 1 laser compliant with according to International Safety Standard IEC-825

Receiver Section

The receiver contain of an InGaAs PIN photodiode coupled to a high sensitivity transimpedance amplifier (TIA) in an OSA. This OSA combination is mated to a post amplifier IC that provides the post amplification and LOS (Loss of Signal) indication circuit, which provides LVTTTL logic high state output when a unusable input optical signal level is detected.

Features

- Small Form Factor Pluggable MSA Compliant
- Linking Distance up to 2 km (50/125µm MMF)
- Compliant with IEEE802.3z Gigabit Ethernet
- Compliant with Fiber Channel
- TTL Signal Detect Indicator
- For Multi-Mode Applications
- LC Duplex Connector
- Single + 3.3 V power Supply
- EEPROM with serial ID functionality.
- Class 1 Laser Safety Standard IEC 825 Compliant
- Temperature: 0 to 70°C or -40 to +85°C (Industrial)
- RoHS Compliant

Applications

- Gigabit Ethernet / Fiber Channel

General Specifications

Parameter	Symbol	Min	Typ	Max	Unit
Power Supply Voltage	V _{CC}	0	-	3.6	V
Power Supply Current	I _{CC}	-	-	300	mA
Operating Temperature (Standard)	T _{OP}	0	-	+70	°C
Operating Temperature (Industrial)	T _{OPI}	-40	-	+85	°C
Storage Temperature	T _S	-40	-	+85	°C
Data Rate	B	-	1250	-	Mbps
Supported Link Length on 50/125µm MMF	L	-	2	-	Km

Order Information

Models	P/No.	Bit Rate (Mbps)	Distance (km)	Wavelength (nm)	Fiber Single/Dual	Package	Temp (°C)	TX Power (dBm)	RX Sens. (dBm)	DMI
SFG-MM2	NM3112-02	1250	2	1310	Dual MMF	LC SFP	0 to 70	-10 to -14	-22	No
SFG-MM2-I	NM3112-02-I	1250	2	1310	Dual MMF	LC SFP	-40 to 85	-10 to -14	-22	No

Optical and Electrical Characteristics

Transmitter Electrical Characteristics					
Parameter	Symbol	Min	Typ	Max	Unit
Supply Voltage	V_{CC}	3.15	3.3	3.45	V
Supply Current	I_{CC}	-	-	160	mA
Data Differential Input Voltage	$V_{in, pp}$	300	-	1600	mV
Disable Input Voltage	$V_{IL} - V_{CC}$	-1.81	-	-1.48	V
Enable Input Voltage	$V_{IH} - V_{CC}$	-1.16	-	-0.88	V
Transmitter Optical Characteristics					
Parameter	Symbol	Min	Typ	Max	Unit
Output Optical Power	P_O	-14	-	-10	dBm
Center Wavelength	λ_C	1260	1310	1360	nm
Spectral Width (RMS)	$\Delta\lambda$	-	-	5	nm
Optical Rise Time (10%-90%)	t_r	-	-	0.26	ns
Optical Fall Time (10%-90%)	t_f	-	-	0.26	ns
Extinction Ratio	ER	8.2	-	-	dB

Receiver Electrical Characteristics					
Parameter	Symbol	Min	Typ	Max	Unit
Supply Voltage	V_{CC}	3.15	3.3	3.45	V
Supply Current	I_{CC}	-	-	100	mA
Data Differential Output Voltage	$V_{out, pp}$	300	-	1000	mV
Data Output Rise Time (10%-90%)	t_r	-	-	0.35	ns
Data Output Fall Time (10%-90%)	t_f	-	-	0.35	ns
Receiver Optical Characteristics					
Parameter	Symbol	Min	Typ	Max	Unit
Maximum Receiver Power	P_{in}	-3	-	-	dBm
Receiver Sensitivity	P_S	-	-22	-	dBm
Optical Center Wavelength	λ_C	1260	-	1600	nm
Signal Detect-Asserted	P_A	-	-	-23	dBm avg.
Signal Detect-Deasserted	P_D	-45	-	-	dBm avg.
Signal Detect-Hysteresis	$P_A - P_D$	0.5	-	-	dB

Recommended Circuit Schematic

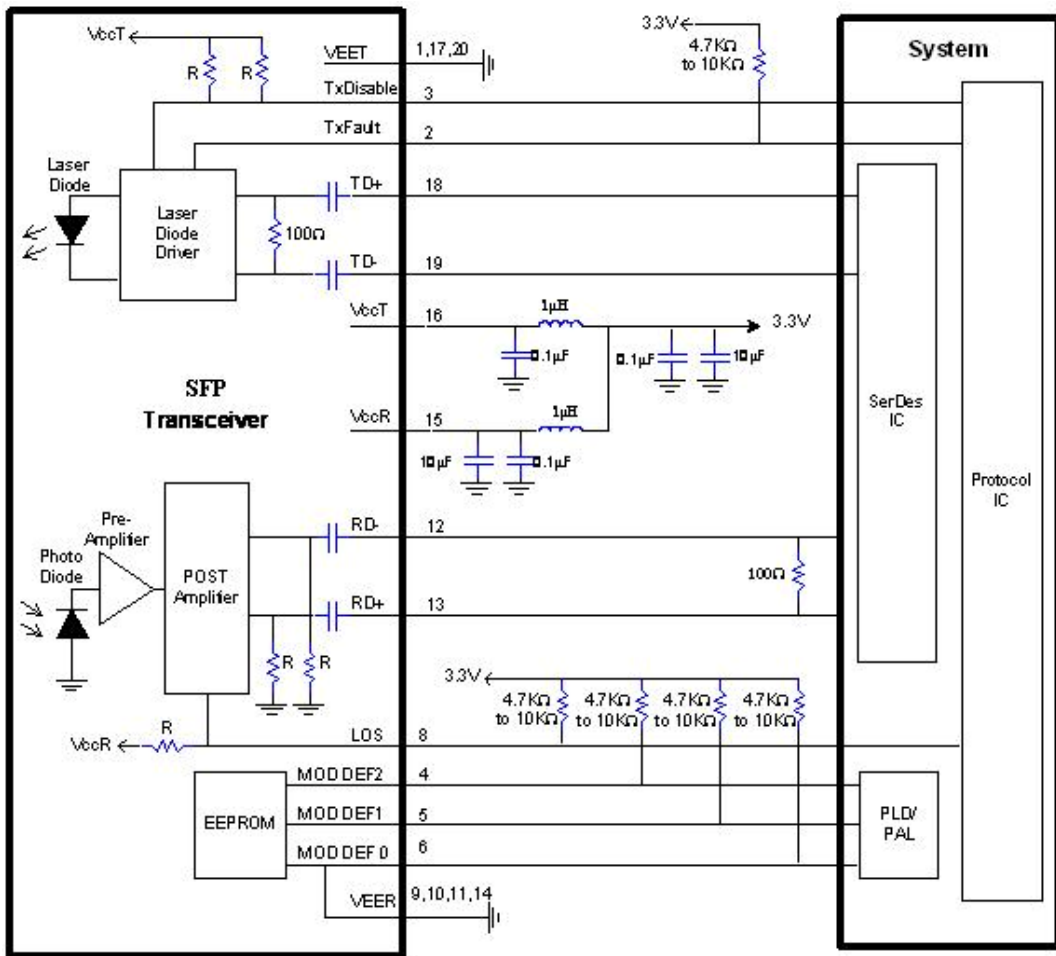

Package Outline Drawing

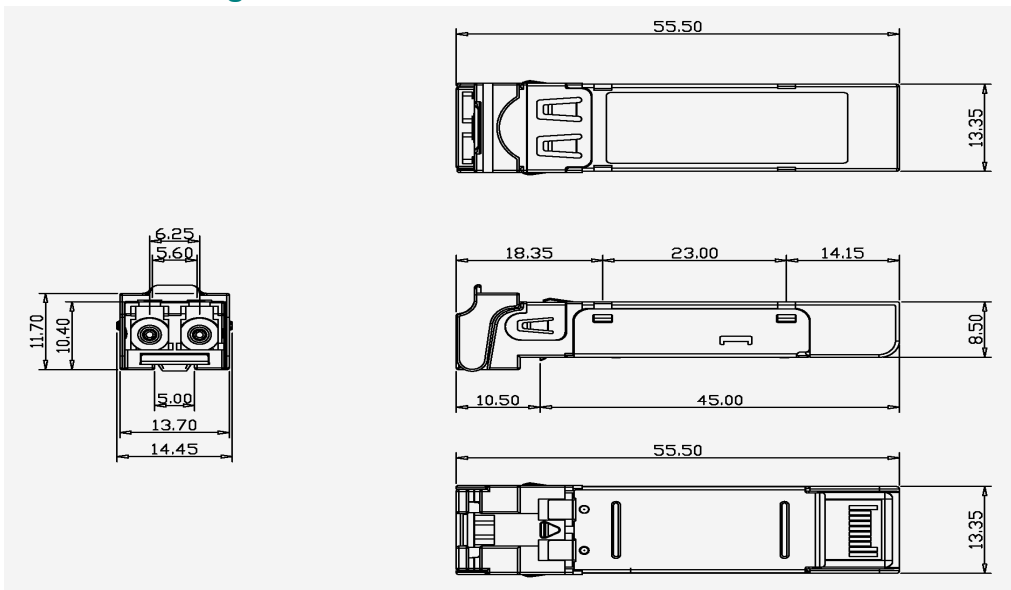

Dimension (unit: mm)

SFP Transceiver Electrical Pad Layout

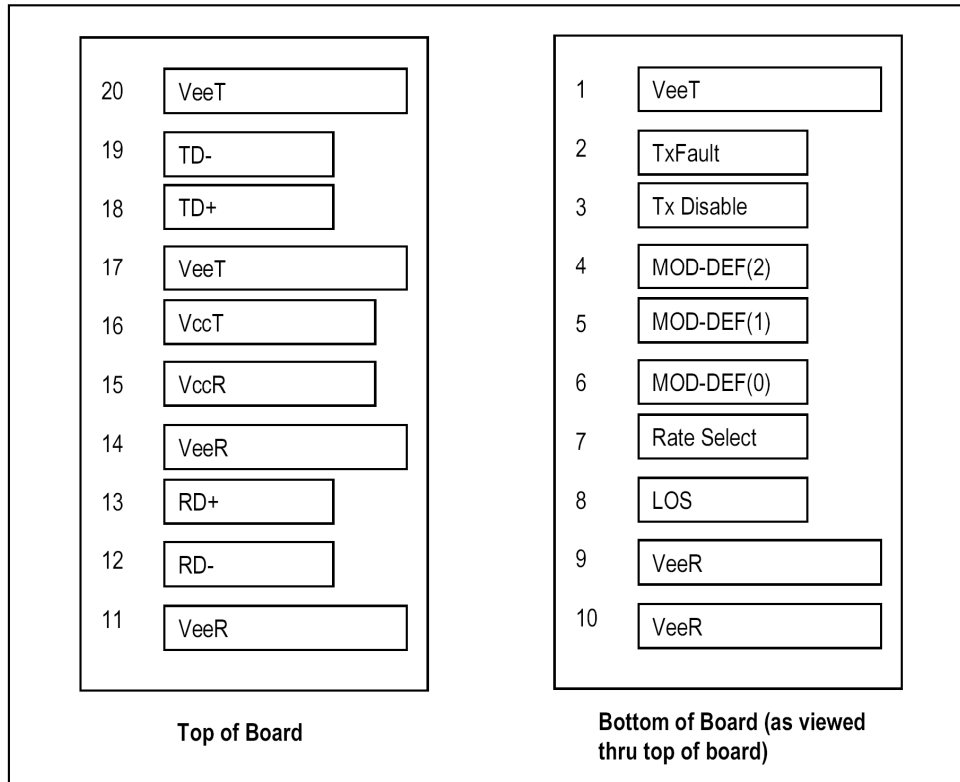

Pinout Table

Pin	Symbol	Name/Description	Ref.
1	V _{EET}	Transmitter Ground	1
2	T _{FAULT}	Transmitter Fault.	4
3	T _{DIS}	Transmitter Disable. Laser output disabled on high or open.	2
4	MOD_DEF (2)	Module Definition 2. Data line for Serial ID.	3
5	MOD_DEF (1)	Module Definition 1. Clock line for Serial ID.	3
6	MOD_DEF (0)	Module Definition 0. Grounded within the module.	3
7	Rate Select	No connection required	
8	LOS	Loss of Signal indication. Logic 0 indicates normal operation.	
9	V _{EER}	Receiver Ground	1
10	V _{EER}	Receiver Ground	1
11	V _{EER}	Receiver Ground	1
12	RD-	Receiver Inverted DATA out. AC Coupled	
13	RD+	Receiver Non-inverted DATA out. AC Coupled	
14	V _{EER}	Receiver Ground	1
15	V _{CCR}	Receiver Power Supply	
16	V _{CCT}	Transmitter Power Supply	
17	V _{EET}	Transmitter Ground	1
18	TD+	Transmitter Non-Inverted DATA in. 100 ohm termination between TD+ and TD-, AC Coupled thereafter.	
19	TD-	Transmitter Inverted DATA in. See TD+	
20	V _{EET}	Transmitter Ground	1

Notes:

- Laser output disabled on TDIS >2.0V or open, enabled on TDIS <0.8V.
- Should be pulled up with 4.7k – 10kohms on host board to a voltage between 2.0V and 5.5V. MOD_DEF (0) pulls line low to indicate module is plugged in.
- TX-Fault is open collector output. Should be pulled up with 4.7k – 10k ohms on host board to a voltage between 2.0V and 5.5V.
- LOS is open collector output. Should be pulled up with 4.7k – 10k ohms on host board to a voltage between 2.0V and 5.5V.