

Description

General

The SFG-W04 are small form factor pluggable modules for bi-directional serial optical data communications such as Gigabit Ethernet IEEE802.3z and Fiber Channel. These modules are designed for single mode fiber with high performance by using 1310 / 1550 nm wavelength. It is with the SFP 20-pin connector to allow hot plug capability.



Transmitter Section

The transmitter consists of a high-performance 1310 nm DFB or 1550 nm MQW DFB structure lasers in the bi-directional optical subassembly (BOSA), which is housed within a metal package. In addition, this component is also class 1 laser compliant with according to International Safety Standard IEC-825.

Receiver Section

The receiver contain of an integrated planar InGaAs PIN photodiode coupled to a high sensitivity trans-impedance amplifier (TIA) in an BOSA. This BOSA combination is mated to a post amplifier IC that provides the post amplification and SD (Signal Detect) indication circuit, which provides LVTTTL logic low state output when an unusable input optical signal level is detected.

Features

- Small Form Factor Pluggable MSA Compliant
- Bi-directional Linking Distance Up to 40 km (21dB)
- Compliant with IEEE 802.3z Gigabit Ethernet
- Compliant with Fiber Channel
- TTL Signal Detect Indicator
- SC or LC Simplex Connector
- EEPROM with serial ID functionality
- Class 1 Laser Safety Standard IEC 825 Compliant
- Single + 3.3 V power Supply
- Temperature: 0 to 70°C or -40 to +85°C (Industrial)
- RoHS Compliant

Applications

- Gigabit Ethernet / Fiber Channel

General Specifications

Parameter	Symbol	Min	Typ	Max	Unit
Power Supply Voltage	V _{CC}	0	-	3.6	V
Power Supply Current	I _{CC}	-	-	300	mA
Operating Temperature (Standard)	T _{OP}	0	-	+70	°C
Operating Temperature (Industrial)	T _{OPI}	-40	-	+85	°C
Storage Temperature	T _S	-40	-	+85	°C
Data Rate	B	-	1250	-	Mbps
Supported Link Length on 9/125µm SMF	L	-	40	-	Km

Order Information

Models	P/No.	Bit Rate (Mbps)	Distance (km)	Wavelength (nm)	Package	Temp	TX Power (dBm)	RX Sens. (dBm)	DMI
SFG-W04/A	NC3112-40	1250	40	Tx-1310/ Rx-1550	SC SFP	0 to 70	2 to -3	-23	No
SFG-W04/B	NC5512-40	1250	40	Tx-1550/ Rx-1310	SC SFP	0 to 70	2 to -3	-23	No
SFG-W04/AL-D	NK3112-40-D	1250	40	Tx-1310/ Rx-1550	LC SFP	0 to 70	2 to -3	-23	Yes
SFG-W04/BL-D	NK5512-40-D	1250	40	Tx-1550/ Rx-1310	LC SFP	0 to 70	2 to -3	-23	Yes
SFG-W04/A-I	NC3112-40-I	1250	40	Tx-1310/ Rx-1550	SC SFP	-40 to 85	2 to -3	-23	No
SFG-W04/B-I	NC5512-40-I	1250	40	Tx-1550/ Rx-1310	SC SFP	-40 to 85	2 to -3	-23	No
SFG-W04/A-DI	NC3112-40-DI	1250	40	Tx-1310/ Rx-1550	SC SFP	-40 to 85	2 to -3	-23	Yes
SFG-W04/B-DI	NC5512-40-DI	1250	40	Tx-1550/ Rx-1310	SC SFP	-40 to 85	2 to -3	-23	Yes

BULGARIA

| Network Logic Ltd.
| Tel: +359 2 974 3030

RUSSIA

| Network Logic Ltd.
| Tel: +7 495 984 7673

TAIWAN

| Network Logic Technologies Co. Ltd.
| Tel: +886 2 2656 0139

Optical and Electrical Characteristics

Transmitter Electrical Characteristics					
Parameter	Symbol	Min	Typ	Max	Unit
Supply Voltage	V_{CC}	3.15	3.3	3.45	V
Supply Current	I_{CC}	-	-	160	mA
Data Differential Input Voltage	$V_{in, pp}$	300	-	1600	mV
Disable Input Voltage	$V_{IL} - V_{CC}$	-1.81	-	-1.48	V
Enable Input Voltage	$V_{IH} - V_{CC}$	-1.16	-	-0.88	V
Transmitter Optical Characteristics					
Parameter	Symbol	Min	Typ	Max	Unit
Output Optical Power	P_O	-3	-	+2	dBm
Center Wavelength NK3112-40ATO	λ_C	1290	1310	1330	nm
Center Wavelength NK5512-40ATO	λ_C	1530	1550	1570	nm
Spectral Width (RMS)	$\Delta\lambda$	-	1	-	nm
Optical Rise Time (10%-90%)	t_r	-	-	0.26	ns
Optical Fall Time (10%-90%)	t_f	-	-	0.26	ns
Extinction Ratio	ER	8.2	-	-	dB

Receiver Electrical Characteristics					
Parameter	Symbol	Min	Typ	Max	Unit
Supply Voltage	V_{CC}	3.15	3.3	3.45	V
Supply Current	I_{CC}	-	-	100	mA
Data Differential Output Voltage	$V_{out, pp}$	300	-	1000	mV
Data Output Rise Time (10%-90%)	t_r	-	-	0.35	ns
Data Output Fall Time (10%-90%)	t_f	-	-	0.35	ns
Receiver Optical Characteristics					
Parameter	Symbol	Min	Typ	Max	Unit
Maximum Receiver Power	P_{in}	-3	-	-	dBm
Receiver Sensitivity	P_S	-	-23	-	dBm
Optical Center Wavelength NK3112-40ATO	λ_C	1480	-	1600	nm
Optical Center Wavelength NK5512-40ATO	λ_C	1250	-	1350	nm
Signal Detect-Asserted	P_A	-	-	-23	dBm avg.
Signal Detect-Deasserted	P_D	-36	-	-	dBm avg.
Signal Detect-Hysteresis	$P_A - P_D$	0.5	-	-	dB

Recommended Circuit Schematic

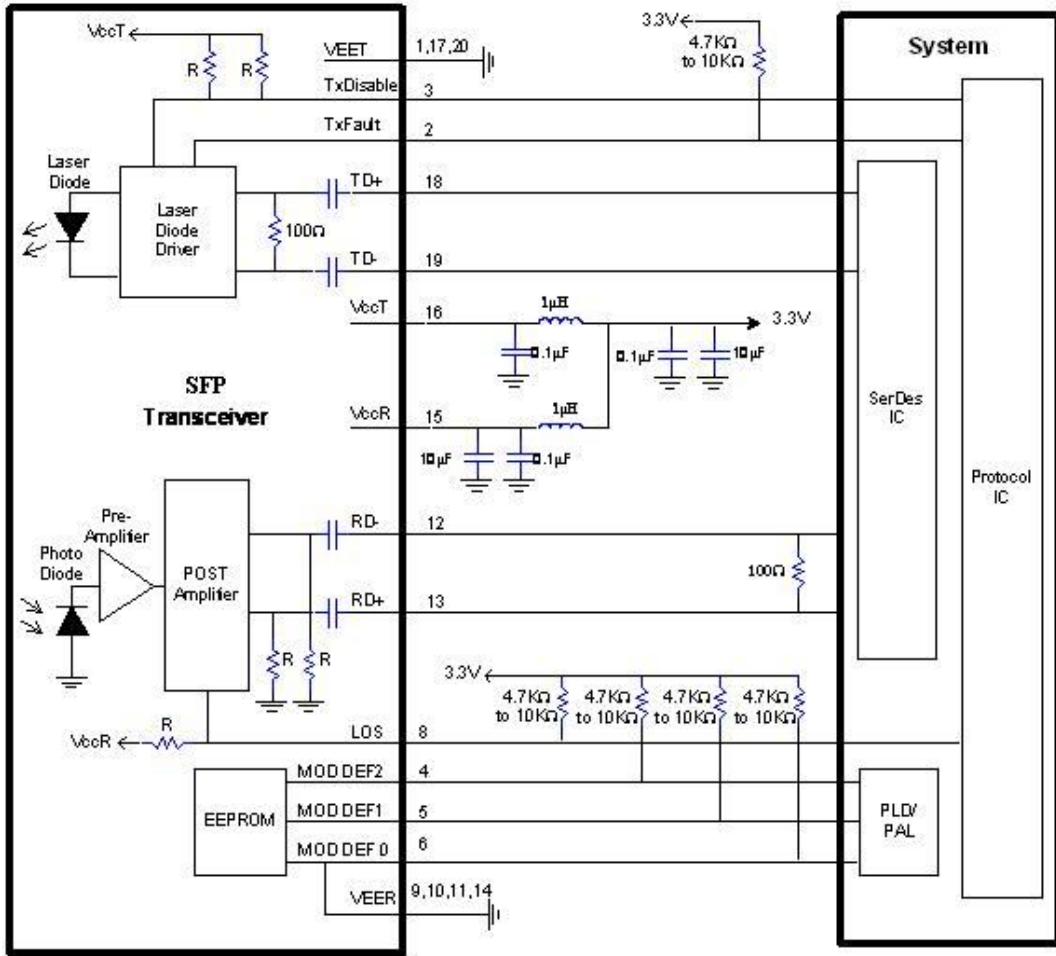

Package Outline Drawing

Dimension (unit: mm)

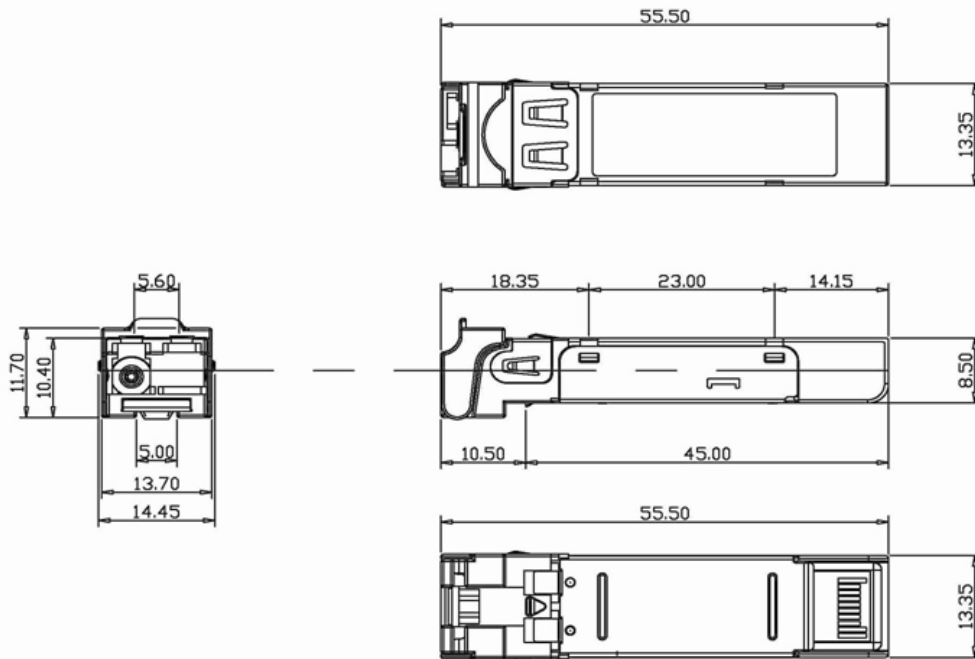

SFP Transceiver Electrical Pad Layout

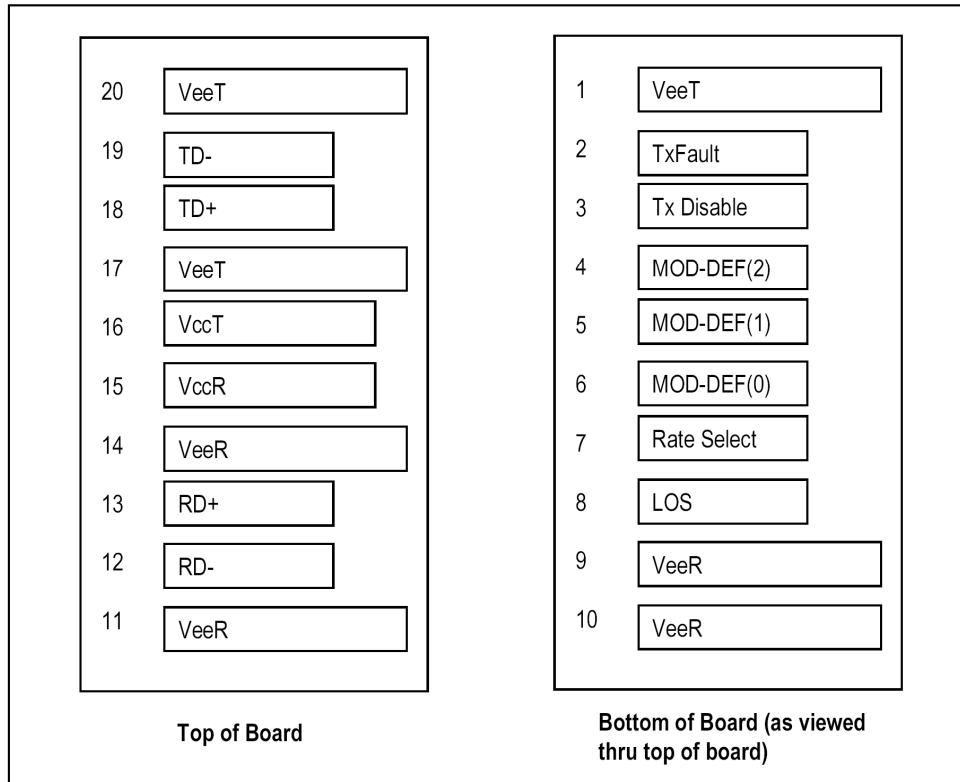

Pinout Table

Pin	Symbol	Name/Description	Ref.
1	V _{EET}	Transmitter Ground	1
2	T _{FAULT}	Transmitter Fault.	4
3	T _{DIS}	Transmitter Disable. Laser output disabled on high or open.	2
4	MOD_DEF (2)	Module Definition 2. Data line for Serial ID.	3
5	MOD_DEF (1)	Module Definition 1. Clock line for Serial ID.	3
6	MOD_DEF (0)	Module Definition 0. Grounded within the module.	3
7	Rate Select	No connection required	
8	LOS	Loss of Signal indication. Logic 0 indicates normal operation.	
9	V _{EER}	Receiver Ground	1
10	V _{EER}	Receiver Ground	1
11	V _{EER}	Receiver Ground	1
12	RD-	Receiver Inverted DATA out. AC Coupled	
13	RD+	Receiver Non-inverted DATA out. AC Coupled	
14	V _{EER}	Receiver Ground	1
15	V _{CCR}	Receiver Power Supply	
16	V _{CCT}	Transmitter Power Supply	
17	V _{EET}	Transmitter Ground	1
18	TD+	Transmitter Non-Inverted DATA in. 100 ohm termination between TD+ and TD-, AC Coupled thereafter.	
19	TD-	Transmitter Inverted DATA in. See TD+	
20	V _{EET}	Transmitter Ground	1

Notes:

- Laser output disabled on TDIS >2.0V or open, enabled on TDIS <0.8V.
- Should be pulled up with 4.7k – 10kohms on host board to a voltage between 2.0V and 5.5V. MOD_DEF (0) pulls line low to indicate module is plugged in.
- TX-Fault is open collector output. Should be pulled up with 4.7k – 10k ohms on host board to a voltage between 2.0V and 5.5V.
- LOS is open collector output. Should be pulled up with 4.7k – 10k ohms on host board to a voltage between 2.0V and 5.5V.