

Description

General

The SF-W04 is small form factor pluggable modules for serial optical data Communications applications specify of SONET OC-3 / SDH STM-1 / IEEE 802.3u. These modules are designed for single mode fiber with cost effective and high performance by using 1310/ 1550nm wavelength. It is with the SFP 20-pin connector to allow hot plug capability.



Transmitter Section

The transmitter consists of a high-performance 1310 nm or 1550 nm Fabry-Perot (FP) laser in the bi-directional optical subassembly (BOSA), which is housed within a metal package. In addition, this component is also class 1 laser compliant with according to International Safety Standard IEC-825.

Receiver Section

The receiver contain of an integrated planar InGaAs PIN photodiode coupled to a high sensitivity trans-impedance amplifier (TIA) in an BOSA. This BOSA combination is mated to a post amplifier IC that provides the post amplification and SD (Signal Detect) indication circuit, which provides LVTTTL logic low state output when an unusable input optical signal level is detected

Features

- Small Form Factor Pluggable MSA Compliant
- Bi-directional Linking Distance Up to 40 km
- PECL Differential Inputs and Outputs
- TTL Signal Detect Indicator
- For Single Mode Applications
- SC or LC Simplex Connector
- EEPROM with serial ID functionality
- Class 1 Laser Safety Standard IEC 825 Compliant
- Single + 3.3 V power Supply
- Temperature Ranges: 0°C to +70°C
- RoHS Compliant

Applications

- Fast Ethernet Links, SONET/SDH Equipment
- Bridges/Routers/intelligent hub and concentrators

Absolute Maximum Ratings					
Parameter	Symbol	Min	Typ	Max	Unit
Storage Temperature	T _S	-40	-	85	°C
Operating Temperature	T _{OP}	0	-	70	°C
Power Supply Voltage	V _{CC}	0	-	3.6	V
Power Supply Current	I _{CC}	-	-	200	mA
General Specifications					
Parameter	Symbol	Min	Typ	Max	Units
Data Rate	B	-	155	-	Mbps
Supported Link Length on 9/125µm SMF	L	-	40	-	Km

Order Information

Models	P/No.	Bit Rate (Mbps)	Distance (km)	Wavelength (nm)	Fiber Single/Dual	Package	Temp. (°C)	TX Power (dBm)	RX Sens. (dBm)
SF-W04	NK3115-40	125 / 155	40	Tx-1310/ Rx-1550	Single	LC SFP	0 to70	-3 to -8	-34
	NK5515-40	125 / 155	40	Tx-1550/ Rx-1310	Single	LC SFP	0 to70	-3 to -8	-34

Optical and Electrical Characteristics

Transmitter Electrical Characteristics					
Parameter	Symbol	Min	Typ	Max	Unit
Supply Voltage	V_{CC}	3.15	3.3	3.45	V
Supply Current	I_{CC}	-	-	160	mA
Data Differential Input Voltage	$V_{in, pp}$	300	-	1600	mV
Disable Input Voltage	$V_{IL} - V_{CC}$	-1.81	-	-1.48	V
Enable Input Voltage	$V_{IH} - V_{CC}$	-1.16	-	-0.88	V
Transmitter Optical Characteristics					
Parameter	Symbol	Min	Typ	Max	Unit
Output Optical Power	P_O	-8	-	-3	dBm
Center Wavelength NK3115-40ATO	λ_C	1280	1310	1340	nm
Center Wavelength NK5515-40ATO	λ_C	1530	1550	1570	nm
Spectral Width (RMS) NK3115-40ATO	$\Delta\lambda$	-	2	-	nm
Spectral Width (RMS) NK5515-40ATO	$\Delta\lambda$	-	1	-	nm
Optical Rise Time (10%-90%)	t_r	-	-	2	ns
Optical Fall Time (10%-90%)	t_f	-	-	2	ns
Extinction Ratio	ER	10	-	-	dB

Receiver Electrical Characteristics					
Parameter	Symbol	Min	Typ	Max	Unit
Supply Voltage	V_{CC}	3.15	3.3	3.45	V
Supply Current	I_{CC}	-	-	100	mA
Data Differential Output Voltage	$V_{out, pp}$	300	-	1000	mV
Data Output Rise Time (10%-90%)	t_r	-	-	0.35	ns
Data Output Fall Time (10%-90%)	t_f	-	-	0.35	ns
Receiver Optical Characteristics					
Parameter	Symbol	Min	Typ	Max	Unit
Maximum Receiver Power	P_{in}	-3	-	-	dBm
Receiver Sensitivity	P_S	-	-34	-	dBm
Optical Center Wavelength NK3115-40ATO	λ_C	1480	-	1600	nm
Optical Center Wavelength NK5515-40ATO	λ_C	1250	-	1350	nm
Signal Detect-Asserted	P_A	-	-	-34	dBm avg.
Signal Detect-Deasserted	P_D	-46	-	-	dBm avg.
Signal Detect-Hysteresis	$P_A - P_D$	0.5	-	-	dB

Recommended Circuit Schematic

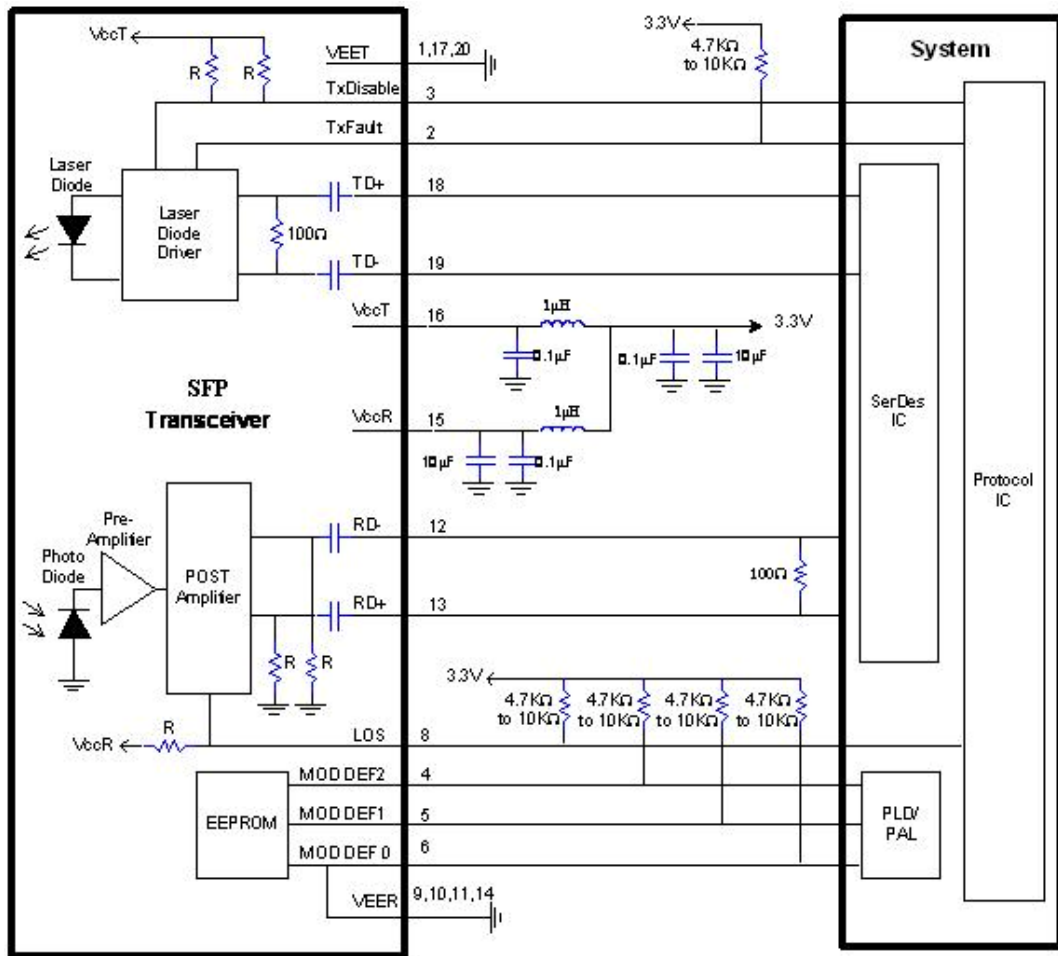

Package Outline Drawing

Dimension (unit: mm)

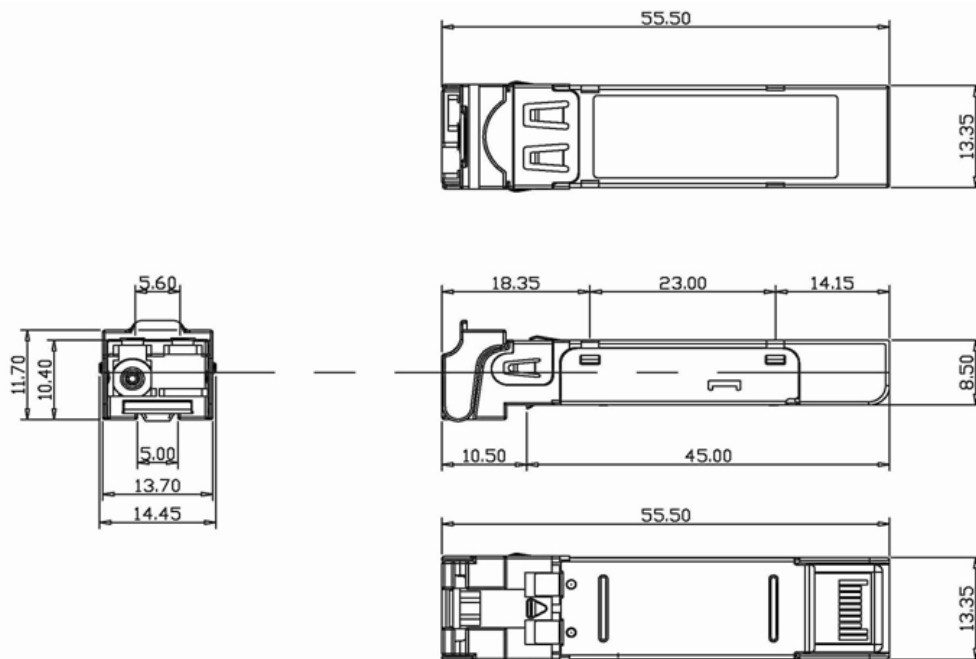

SFP Transceiver Electrical Pad Layout

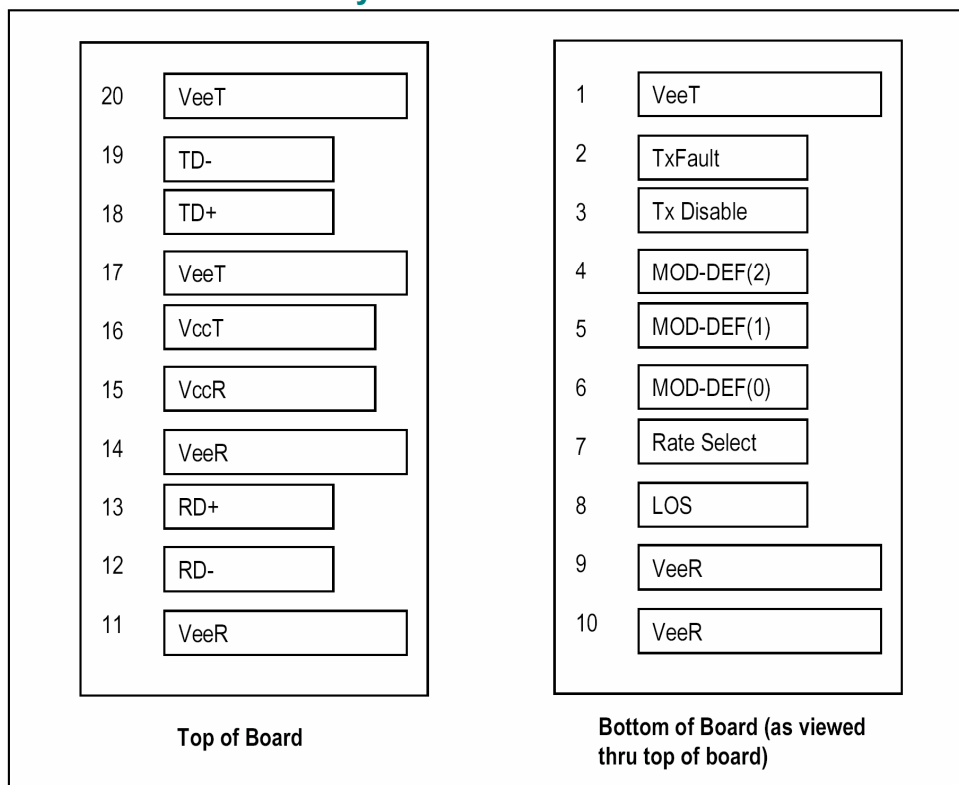

Pinout Table

Pin	Symbol	Name/Description	Ref.
1	V _{EET}	Transmitter Ground	1
2	T _{FAULT}	Transmitter Fault.	4
3	T _{DIS}	Transmitter Disable. Laser output disabled on high or open.	2
4	MOD_DEF (2)	Module Definition 2. Data line for Serial ID.	3
5	MOD_DEF (1)	Module Definition 1. Clock line for Serial ID.	3
6	MOD_DEF (0)	Module Definition 0. Grounded within the module.	3
7	Rate Select	No connection required	
8	LOS	Loss of Signal indication. Logic 0 indicates normal operation.	
9	V _{EER}	Receiver Ground	1
10	V _{EER}	Receiver Ground	1
11	V _{EER}	Receiver Ground	1
12	RD-	Receiver Inverted DATA out. AC Coupled	
13	RD+	Receiver Non-inverted DATA out. AC Coupled	
14	V _{EER}	Receiver Ground	1
15	V _{CCR}	Receiver Power Supply	
16	V _{CCT}	Transmitter Power Supply	
17	V _{EET}	Transmitter Ground	1
18	TD+	Transmitter Non-Inverted DATA in. 100 ohm termination between TD+ and TD-, AC Coupled thereafter.	
19	TD-	Transmitter Inverted DATA in. See TD+	
20	V _{EET}	Transmitter Ground	1

Notes:

- Laser output disabled on TDIS >2.0V or open, enabled on TDIS <0.8V.
- Should be pulled up with 4.7k – 10kohms on host board to a voltage between 2.0V and 5.5V. MOD_DEF (0) pulls line low to indicate module is plugged in.
- TX-Fault is open collector output. Should be pulled up with 4.7k – 10k ohms on host board to a voltage between 2.0V and 5.5V.
- LOS is open collector output. Should be pulled up with 4.7k – 10k ohms on host board to a voltage between 2.0V and 5.5V.